

**EUROPEAN STANDARD  
NORME EUROPÉENNE  
EUROPÄISCHE NORM**

**EN ISO 16582**

November 2002

ICS 21.060.40

**English version**

**Open end blind rivets with break pull mandrel and  
protruding head – Cu/St or Cu/Br or Cu/SSt**  
(ISO 16582 : 2002)

Rivets aveugles à rupture de tige à  
corps ouvert, à tête bombée – Cu/St ou  
Cu/Br ou Cu/SSt (ISO 16582 : 2002)

Offene Blindniete mit Sollbruchdorn  
und Flachkopf – Cu/St oder Cu/Br  
oder Cu/SSt (ISO 16582 : 2002)

This European Standard was approved by CEN on 2002-10-14.

CEN members are bound to comply with the CEN/CENELEC Internal Regulations which stipulate the conditions for giving this European Standard the status of a national standard without any alteration.

Up-to-date lists and bibliographical references concerning such national standards may be obtained on application to the Management Centre or to any CEN member.

The European Standards exist in three official versions (English, French, German). A version in any other language made by translation under the responsibility of a CEN member into its own language and notified to the Management Centre has the same status as the official versions.

CEN members are the national standards bodies of Austria, Belgium, the Czech Republic, Denmark, Finland, France, Germany, Greece, Iceland, Ireland, Italy, Luxembourg, Malta, the Netherlands, Norway, Portugal, Spain, Sweden, Switzerland, and the United Kingdom.

**CEN**

European Committee for Standardization  
Comité Européen de Normalisation  
Europäisches Komitee für Normung

**Management Centre: rue de Stassart 36, B-1050 Brussels**

## Foreword

International Standard

ISO 16582 : 2002 Open end blind rivets with break pull mandrel and protruding head – Cu/St or Cu/Br or Cu/SSt,

which was prepared by ISO/TC 2 'Fasteners' of the International Organization for Standardization, has been adopted by Technical Committee CEN/TC 185 'Threaded and non-threaded mechanical fasteners and accessories', the Secretariat of which is held by DIN, as a European Standard.

This European Standard shall be given the status of a national standard, either by publication of an identical text or by endorsement, and conflicting national standards withdrawn, by May 2003 at the latest.

In accordance with the CEN/CENELEC Internal Regulations, the national standards organizations of the following countries are bound to implement this European Standard:

Austria, Belgium, the Czech Republic, Denmark, Finland, France, Germany, Greece, Iceland, Ireland, Italy, Luxembourg, Malta, the Netherlands, Norway, Portugal, Spain, Sweden, Switzerland, and the United Kingdom.

## Endorsement notice

The text of the International Standard ISO 16582 : 2002 was approved by CEN as a European Standard without any modification.

## 1 Scope

This International Standard specifies dimensional and mechanical characteristics and application data for open end blind rivets with break pull mandrel and protruding head, with a copper body (Cu) and either a steel (St) or a bronze (Br) or a stainless steel (SSt) mandrel and with nominal diameters,  $d$ , from 3 mm up to and including 4,8 mm.

## 2 Normative references

The following normative documents contain provisions which, through reference in this text, constitute provisions of this International Standard. For dated references, subsequent amendments to, or revisions of, any of these publications do not apply. However, parties to agreements based on this International Standard are encouraged to investigate the possibility of applying the most recent editions of the normative documents indicated below. For undated references, the latest edition of the normative document referred to applies. Members of ISO and IEC maintain registers of currently valid International Standards.

ISO 3269:2000, *Fasteners — Acceptance inspection*

ISO 14588:2000, *Blind rivets — Terminology and definitions*

ISO 14589:2000, *Blind rivets — Mechanical testing*

## 3 Dimensions

### 3.1 General

Symbols and designations of dimensions are specified in ISO 14588.

### 3.2 Rivet dimensions

See Figure 1 and Table 1.

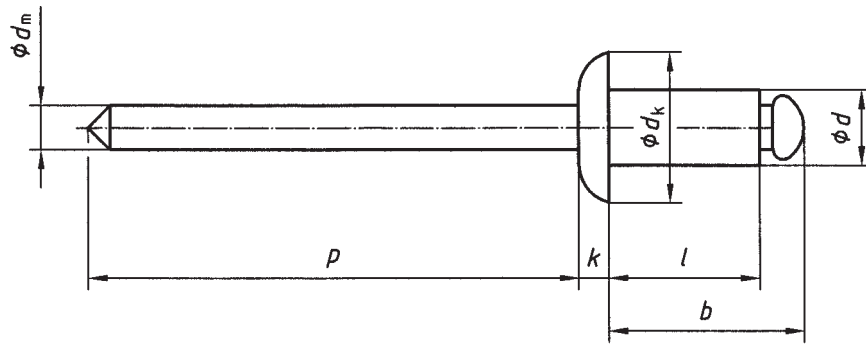

Figure 1 — Rivet dimensions

Table 1 — Rivet dimensions

Dimensions in millimetres

Rivet body	$d$	nom.	3	3,2	4	4,8
		max.	3,08	3,28	4,08	4,88
		min.	2,85	3,05	3,85	4,65
	$d_k$	max.	6,3	6,7	8,4	10,1
		min.	5,4	5,8	6,9	8,3
	$k$	max.	1,3	1,3	1,7	2
Mandrel	$d_m$	max.	2	2	2,45	2,95
	$p$	min.	25	25	25	27
Blind length	$b$	max.	$l_{max} + 3,5$	$l_{max} + 4$	$l_{max} + 4$	$l_{max} + 4,5$
Rivet length		Recommended grip ranges <sup>a</sup>				
$l$						
nom. = min.		max.				
5	6	0,5 to 2,0		1,0 to 2,5		—
6	7	2 to 3		2,5 to 3,5		—
8	9	3 to 5		3,5 to 5,0		2,5 to 4,0
10	11	5 to 7		5 to 7		4 to 6
12	13	7 to 9		7,0 to 8,5		6 to 8
14	15	9 to 11		8,5 to 10,0		8 to 10
16	17	—		10,0 to 12,5		10 to 12
18	19	—		—		12 to 14
20	21	—		—		14 to 16

NOTE The rivet body dimensions are generated from the design formulae specified in annex A.

<sup>a</sup> The grip ranges of rivets with dimensions as given in Table 1, with the material combination as given in clause 4, are specified by the minimum and maximum grip lengths. The minimum grip lengths are recommendations only. It may be possible to go into individual cases below the minimum values.

### 3.3 Clearance hole diameters

The diameters of the clearance holes,  $d_{h1}$ , to accommodate the rivet in the components to be fastened are given in Table 2.

**Table 2 — Clearance hole diameters**

Dimensions in millimetres

$d$ nom.	$d_{h1}$	
	min.	max.
<b>3</b>	3,1	3,2
<b>3,2</b>	3,3	3,4
<b>4</b>	4,1	4,2
<b>4,8</b>	4,9	5,0

Non-conformance to the values listed in Table 2 may result in assembly difficulties and/or reduction in the shear and tensile loads specified in Table 3.

When necessary, to facilitate alignment, only the component on the access side may have a clearance hole larger than specified in Table 2 (see Figure 2). This may also result in a reduction of the shear and tensile loads specified in Table 3.

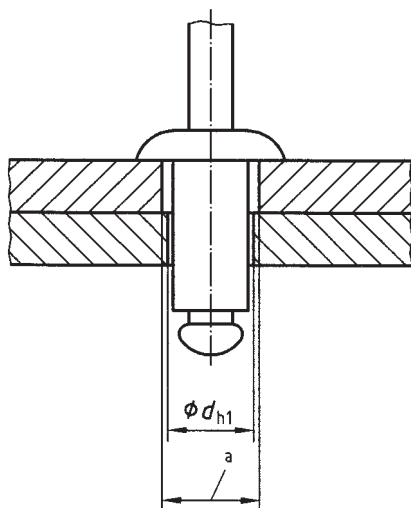

<sup>a</sup> Enlarged clearance hole

**Figure 2 — Enlarged clearance hole to facilitate alignment**

## 4 Material and finish

Blind rivets in accordance with this International Standard shall have a rivet body of copper (Cu) and a mandrel made of either steel (St) or bronze (Br) or stainless steel (SSt) and shall have the mechanical properties as specified in clause 5.

Material specification is at the descretion of the manufacturer.

The surface of the rivet body shall be plain, i.e. in natural finish.

The surface finish of the steel mandrel is at the discretion of the manufacturer and may be phosphate and oil or zinc coating.

The surface of the bronze mandrel shall be plain, i.e. in natural finish.

The surface of the stainless steel mandrel shall be plain, i.e. in natural finish.

## 5 Mechanical properties

The minimum shear load, minimum tensile load and maximum mandrel break load shall be as specified in Table 3 when tested in accordance with ISO 14589.

**Table 3 — Mechanical properties**

<i>d</i> nom. mm	Shear load min. N	Tensile load min. N	Mandrel break load max. N
3	760	950	3 000
3,2	800	1 000	3 000
4	1 500	1 800	4 500
4,8	2 000	2 500	5 000

## 6 Mandrel push-out resistance

The load to push out the mandrel shall exceed 10 N when tested in accordance with ISO 14589.

## 7 Mandrel head retention capability

The portion of the mandrel remaining in the set rivet shall not be ejected by the application of the head retention test load specified in Table 4 when tested in accordance with ISO 14589.

**Table 4 — Mandrel head retention test loads**

<i>d</i> nom. mm	Head retention test load N
3	15
3,2	15
4	20
4,8	25

## 8 Workmanship

Rivets shall be free from burrs and harmful defects and shall have well-formed heads and shanks.

After setting, rivets shall not show evidence of cracking when viewed at 5 × magnification.

## 9 Acceptance testing

If there is no other agreement, acceptance inspection in accordance with ISO 3269 applies.

## 10 Designation

**EXAMPLE** An open end blind rivet, with break pull mandrel and protruding head, with nominal diameter  $d = 4$  mm and nominal length  $l = 12$  mm with a copper body (Cu) and a steel mandrel (St) is designated as follows:

**Blind rivet ISO 16582 - 4 × 12 - Cu/St**

The designation of a rivet with a bronze (Br) or stainless steel (SSt) mandrel shall follow the above example using /Br or /SSt respectively for the last element of the designation.

## Annex A (informative)

### Design formulae

#### A.1 General

Blind rivets in accordance with this International Standard comply with the following design formulae and tolerances.

#### A.2 Shank Diameter

The maximum shank diameter complies with the formula:

$$d_{\max} = d_{\text{nom}} + 0,08 \text{ mm}$$

The minimum shank diameter complies with the formula:

$$d_{\min} = d_{\text{nom}} - 0,15 \text{ mm}$$

#### A.3 Head diameter

The maximum head diameter complies with the formula:

$$d_{k \max} = 2,1 d_{\text{nom}}$$

rounded to one decimal place.

#### A.4 Head diameter tolerance

The head diameter tolerance is h16 for  $d_{\text{nom}} \leq 3,2 \text{ mm}$  and h17 for  $d_{\text{nom}} > 3,2 \text{ mm}$ .

#### A.5 Head height

The maximum head height complies with the formula:

$$k_{\max} = 0,415 d_{\text{nom}}$$

rounded to one decimal place.

#### A.6 Clearance hole diameter

The clearance hole diameter for blind rivet application complies with the formulae:

$$d_{h1 \max} = d_{\text{nom}} + 0,2 \text{ mm}$$

$$d_{h1 \min} = d_{\text{nom}} + 0,1 \text{ mm}$$